

D812M-110

- 120 Vac 60Hz control unit with inverter
- 120 Vac for three-phase motors with delta connections

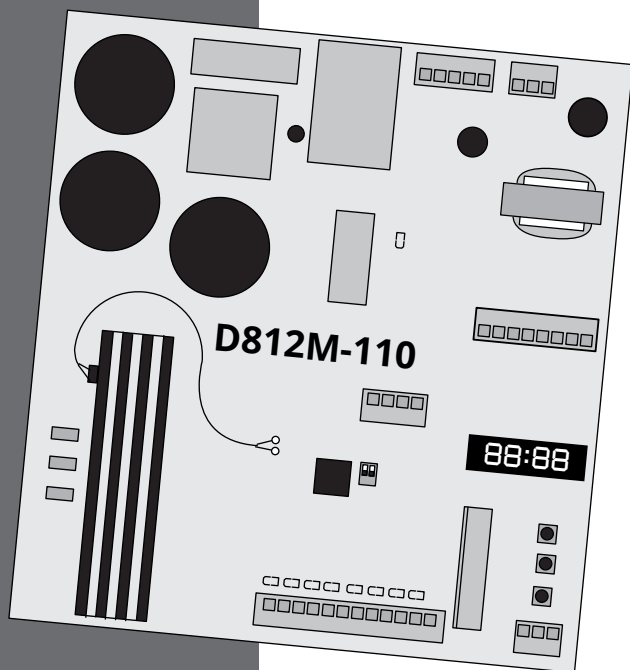

Vers. firmware 1850

D-MNLD812M-110 18-05-2020 - Rev.01

IT - Istruzioni originali



Signal light 120 Vac

For the connection of a 12 Vdc lamp with or without flashing card: See the Page n° 12



120 Vac

AUTOMATIC SWITCH
10/16A

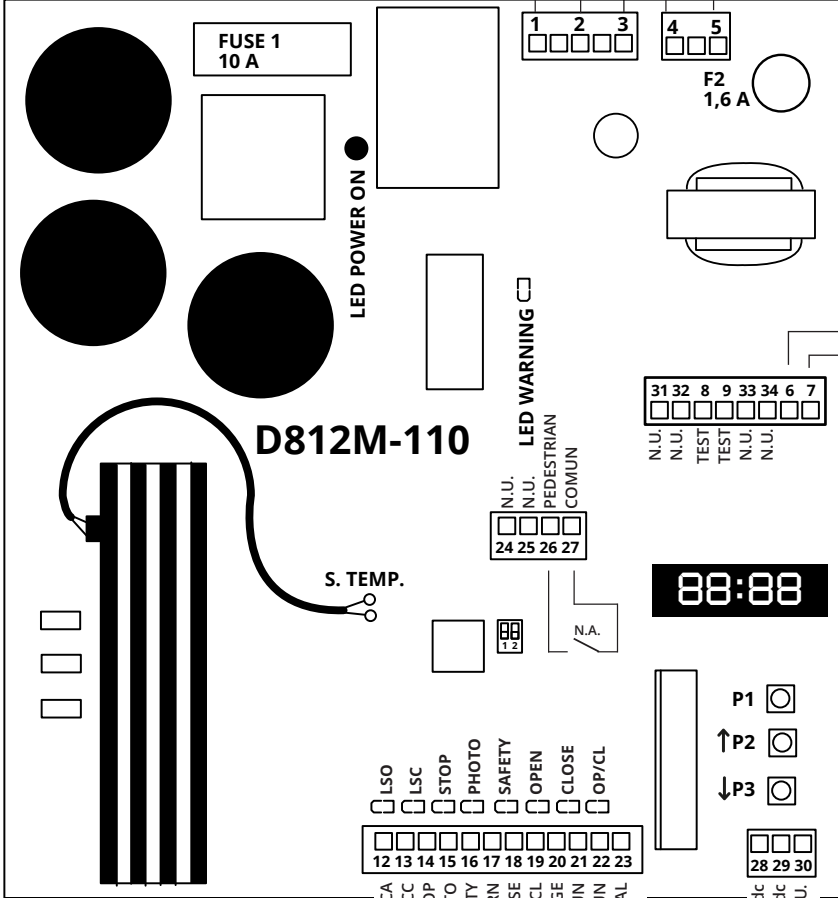

D812M-110

MF1
MF2
MF3

| | |
|-----|---|
| MF1 | Three-phase output for 120 Vac three-phase motors |
| MF2 | |
| MF3 | |

* Connect this point to terminal no. 8 for the photo-test. Otherwise connect it to the terminal board no. 10

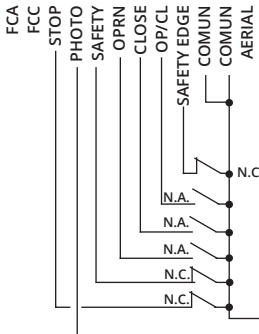

+12 Vdc
-12 Vdc
N.U.

Photocells working in closing

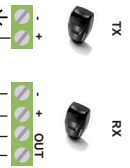

FOREWORD

This manual provides all the specific information you need to familiarize yourself with and correctly operate your unit. Read it very carefully when you purchase the instrument and consult it whenever you have doubts regarding use and before performing any maintenance operations. Nologo has the right to modify the product without previous notice.

ENVIRONMENTAL PROTECTION MEASURES

Information regarding the environment for customers within the European Union. European Directive EC 2002/96 requires that units bearing this symbol on the unit and/or on the packaging be disposed of separately from undifferentiated urban wastes.

The symbol indicates that the product must not be disposed of with the normal household wastes. The owner is responsible for disposing of this product and other electrical and electronic equipment through specific waste collection facilities indicated by the government or local public agencies. Correct disposal and recycling help prevent any potentially negative impact on the environment and human health. To receive more detailed information regarding disposal of your unit, we recommend that you contact the competent public agencies, the waste collection.

Piccola legenda

| | |
|-------------------------|---|
| LSO or FCA | Open limit switch |
| LSC or FCC | Close limit switch |
| OP/CL | Control to drive the gate |
| PEDESTRIAN | in sliding units: control partial opening |
| Vac | (alternate current) alternating voltage |
| Vdc | (discrete current) direct voltage |
| NC | normally closed |
| NA o NO | normally open |
| Isolated contact | isolated from power supply |

INDEX

| Par. | Description | Pag. |
|-----------|--|-----------|
| 1 | Scheme of the control unit | 6 |
| 1.1 | Description of the electrical connections | 8 |
| 2 | Use and functions of the control panel | 9 |
| 2.1 | State of the control unit | 9 |
| 2.2 | Settings and parameters | 9 |
| 2.3 | Example how to use the MENU and information | 10 |
| 2.4 | Set up a password for programming | 10 |
| 2.5 | Display the number of cycles and the speed of the motor | 11 |
| 2.6 | Deactivation of the cycle when the control panel will be turned on | 11 |
| 3 | Installation of the control unit | 12 |
| 3.1 | Connection of the TENSION and MOTOR | 12 |
| 3.2 | Connection of the lamp 230 Vac or 12 Vac | 12 |
| 3.3 | PRE-FLASHING time | 12 |
| 3.4 | Connection of the AERIAL | 13 |
| 3.5 | STOP connection | 13 |
| 3.6 | Connection of the 8k2 safety edge or N.C. | 13 |
| 3.7 | Connection of the Open and Close limit switch | 13 |
| 3.8 | The connection of PEDESTRIAN or OP/CL | 14 |
| 3.9 | Connection of the PHOTOCCELL (only when closing) | 14 |
| 3.10 | Connection of the PHOTOCCELL (activated when closing) with TEST | 15 |
| 4 | ACTIVATE the single OUTPUTS | 15 |
| 5 | Operating modes and adjustments | 16 |
| 5.1 | Logic of functions | 16 |
| 5.2 | Working time | 17 |
| 5.3 | Set SPEED and ACCELERATION | 18 |
| 5.4 | SCHEME relation between SPEED and FRQUENCY of the motor | 19 |
| 6 | RESET of the control unit and restore of factory default settings | 20 |
| 6.1 | Restore factory settings | 20 |
| 6.2 | SAVE SET UP and CHECK of the parameters | 20 |
| 7 | LIST of the FUNCTIONS | 21 |
| 8 | Problems | 25 |
| 9 | Note | 25 |
| 10 | Declaration of CE conformity | 27 |

SAFETY PRECAUTIONS

We remind that the installations of gates and automatic doors must be executed from qualified personnels according to the norms. Before installing check the strength and mechanic part of the gate or door, check that the mechanical stops are suitable to stop immediately the cycle of the gate or door even in case of faulty limit switches or during the manual cycle. For your security we recommend to install a STOP switch when activated it stops immediately the gate. The switch has a N.C. opening in case is activated (as shown in par. no. 3.5)

SYMBOLS AND WARNING



Dangerous

This is a warning and if it is not respect it can provoque material damage



Damage

For safety reasons, protect your face during the connection



Device under tension

The installation should be done only from professional installer



Read carefully the operating manual

Read carefully this manul before installation and keep it for the future



Dangerous for overheated surface

NETWORK FILTER FOR CE NORMS

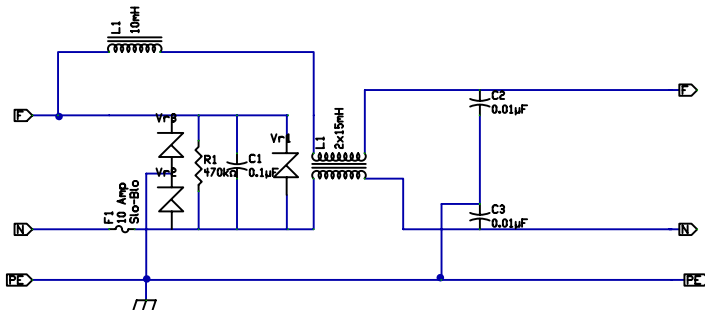

FILTER-S12
Option for CE Norms

TYPE OF INSTALLATION

The control board D812M-110 can be used for Industrial rapid doors and for sliding automation with three-phase motors (delta connection) up to 2 Hp with ventilation systems.

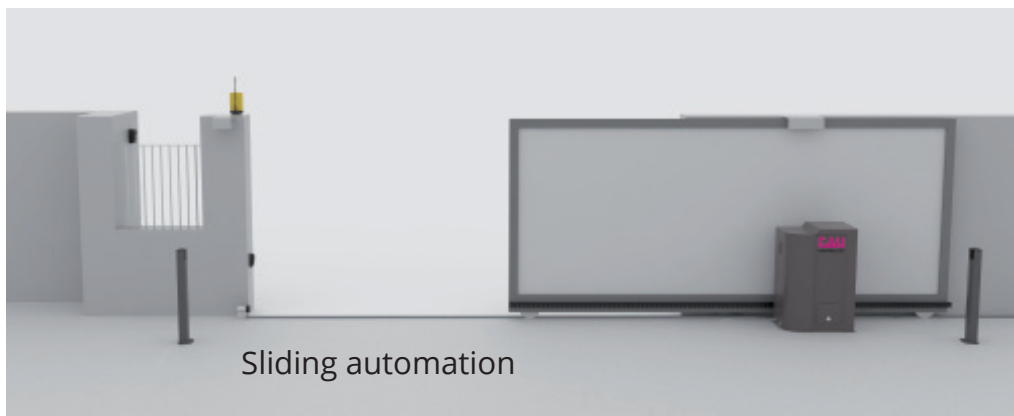

CHECK THE SOFTWARE VERSION AND COMPATIBILITY WITH THE OPERATING MANUAL

When the control unit is turned on, you can see 4 numbers in the display. This is the software number. We suggest to check this number with the version on the manual. (see pic).

CODE

1850

Vers. firmware 1850

! Check that the number on the display correspond to the firmware on the operating manual



1. SCHEME OF THE CONTROL UNIT

LED POWER ON

Indicates the network power



WARNING!

We remind you that the safety devices, accessories should be installed when the control unit is not powered.

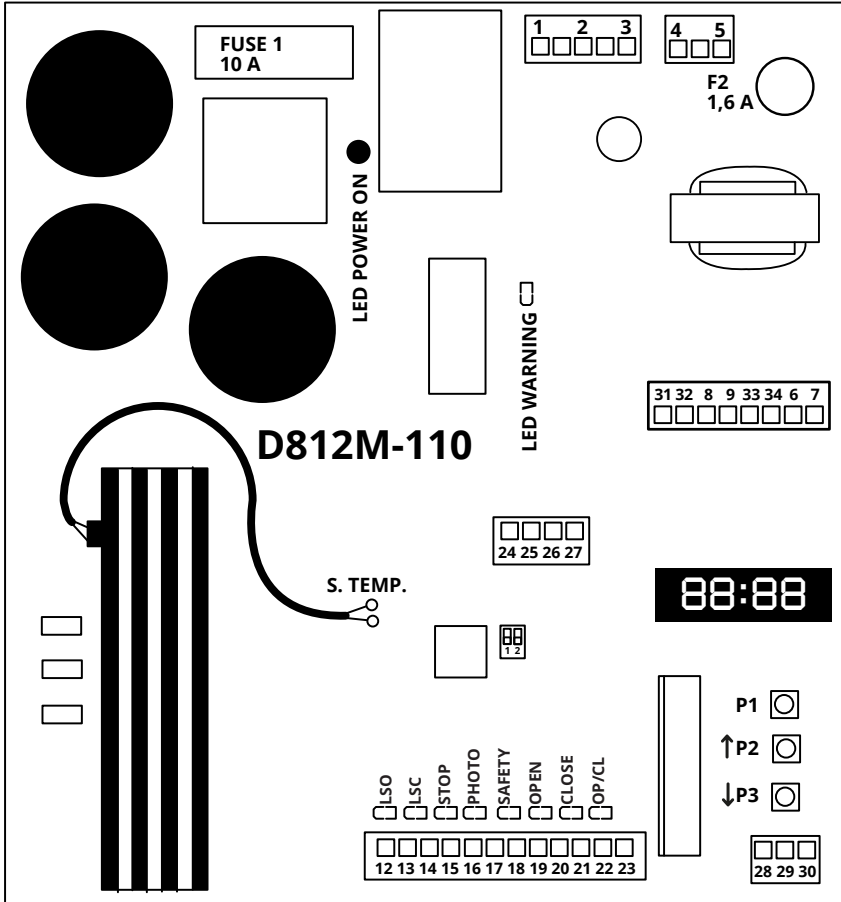

P1 P2 P3 Set the control unit

DIP not used

F1 Fuses protection motor and power: 10A

F2 Fused protection terminal boards (4, 5): 1.6A

MF1-2-3 Three-phases output for 120Vac three-phases motors

LED WARNING Indicates that the capacitors are still charged, before removing the control unit wait for the LED to go off.

The **red led** in the input **LSO-LSC-STOP-PHOTO-SAFETY** are **always lit on**

The **green led** in the inputs **OPEN-CLOSE-OP/CL** are **normally lit off**

LSO **LSC** **STOP** **PHOTO** **SAFETY** **OPEN** **CLOSE** **OP/CL**



WARNING: If the inputs are desactivated from display with **S13, S14, S15, S16, S17** red leds are **SWITCHED OFF**

Recommended wiring diagram

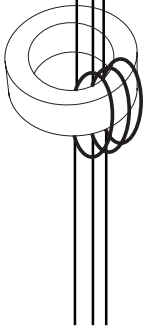
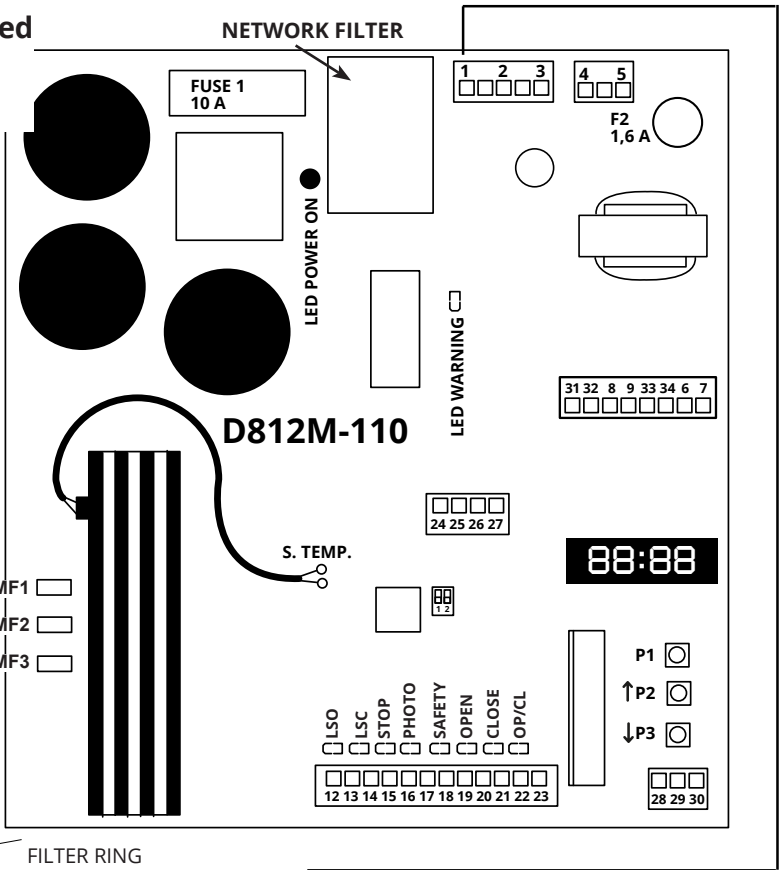

FILTER RING

CABLE MOTOR OUTPUT 1 TURN

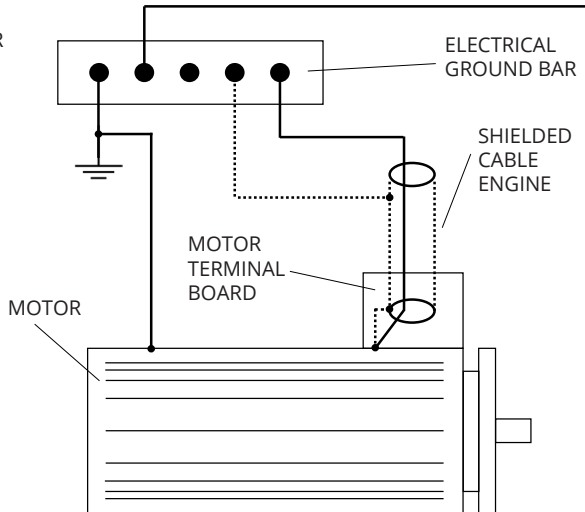

1.1 DESCRIPTION OF THE ELECTRICAL CONNECTIONS



In case of long sections of cables (> 20 m) for N.O./N.C. controls (ex. OPEN/CLOSE, STOP, PEDESTRIAN, etc.), in order to avoid gate malfunctions, it will be necessary to uncouple the various controls using RELAYS or using our 750T-RELE device.

| | | | |
|---------------|----|--|---|
| Earth | 1 | | Earth |
| 120 Vac (N) | 2 | | 120 Vac 60Hz, power supply, neutral |
| 120 Vac (L) | 3 | | 120 Vac 60Hz, power supply, phase |
| Signal light | 4 | | 120 Vac Signal light Max power 40 W |
| | 5 | | |
| Signal light | 6 | | <i>For the connection of a 12 Vdc lamp or 120Vac signal lighth: See the par 3.2, page number 12</i> |
| | 7 | | |
| N.U. | 34 | | NOT USED |
| N.U. | 33 | | NOT USED |
| Test | 9 | | Clean contact for PHOTOCELL TEST |
| Test | 8 | | Clean contact for PHOTOCELL TEST |
| N.U. | 32 | | NOT USED |
| N.U. | 31 | | NOT USED |
| LSO | 12 | | Open limit switch |
| LSC | 13 | | Closing limit switch |
| Stop | 14 | | STOP |
| Photo | 15 | | PHOTO-A closing |
| Safety | 16 | | N.C. contact (see S17 setting) |
| Open | 17 | | OPEN |
| Close | 18 | | CLOSE |
| OP/CL | 19 | | OPEN / CLOSE input |
| Safety edge | 20 | | SAFETY edge - NC / 8k2 contact |
| Common | 21 | | Common Services Safeties |
| Common | 22 | | Antenna Socks / Common-Services-Safeties |
| + Aerial | 23 | | + Aerial |
| N.U. | 24 | | NOT USED |
| N.U. | 25 | | NOT USED |
| Pedestrian | 26 | | Pedestrian |
| Common | 27 | | Common Services Safeties |
| Out + 12 Vdc | 28 | | Output + 12Vdc 60mA auxiliaries |
| Out - 12 Vdc | 29 | | Output - 12Vdc 60mA auxiliaries |
| N.U. | 30 | | NOT USED |
| | | | |

2. USE AND FUNCTIONS OF THE CONTROL PANEL

D812M has a display for a simple and fast programming. The menu has been designed for a clear and fast set up of the working time and the logic of the control unit. You can set up the control unit only when the door is closed.

2.1 STATE OF THE CONTROL UNIT

If no button is pressed, the display shows the position of the automation and the temperature value of the IGBT heat sink.

The display shows 'P.Fcc' on the left and 't23c' on the right, separated by three dots. This indicates the door is closed and the heat sink temperature is 23°C.

In this case the door is with closing limit switch and that the heat temperature is 23°C.

2.2. SETTINGS AND PARAMETERS

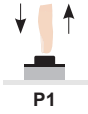

ACCESS TO THE FUNCTIONS
Press **P1** when the gate is closed

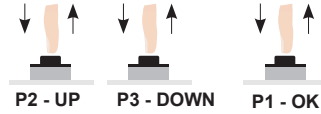

SELECTION OF THE LETTER ADJUSTMENT
Press button **P2** and **P3** to select the group and press **P1** to confirm.

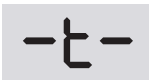

Set up T
Set up of the Time programming



Set up S
Logic of the control unit



Set up L
Set up of the programm (Speed, power...)



Set up R
Activation of the outputs Displays information about the control unit



Set up E
Back to the standard functions

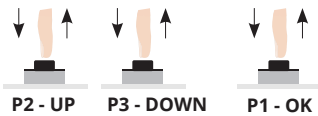

SELECTION OF NUMBER SET UP
Press **P2** and **P3** to select the set up
Press **P1** to confirm

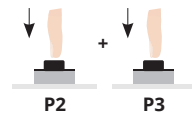

GO BACK
To go back to the previous group press **P2** and **P3**



SELF-RESET
If the control unit is not used for more than one minute, the control unit go out from the programming saving programs and all changes.

2.3. EXAMPLE HOW TO USE THE MENU AND INFORMATION

You can read the information through a display: you can read if it is working properly, the manoeuvre counter and the sink temperature. Some information can be shown only on the **R** function (see Chapter no.4)

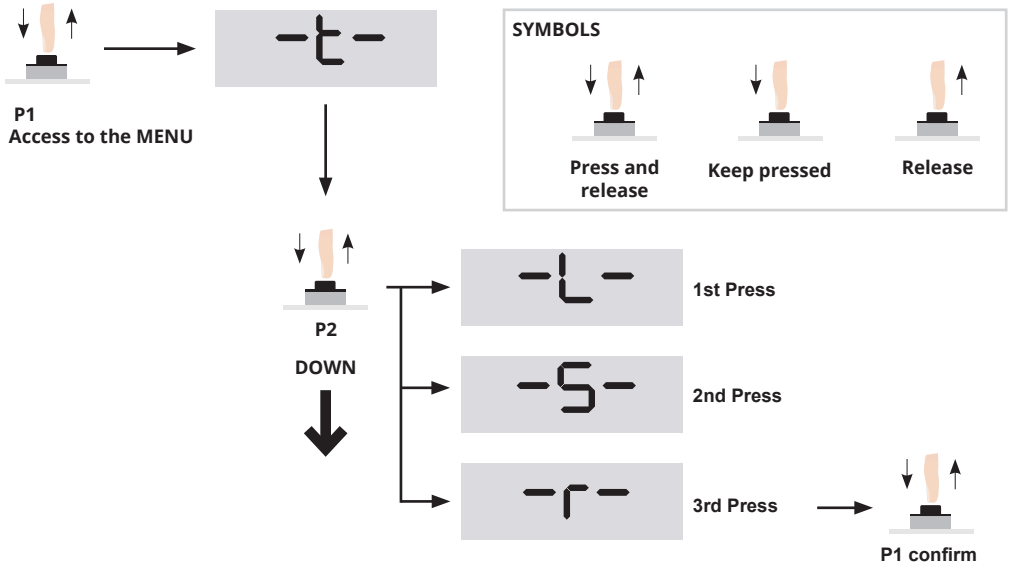

In the function **R** if you press **P1**, you can choose the group function: first select **P2** and **P3** and then confirm with **P1**. Now you can go to the function **R07**, **R08**, **R09** and **R10**.

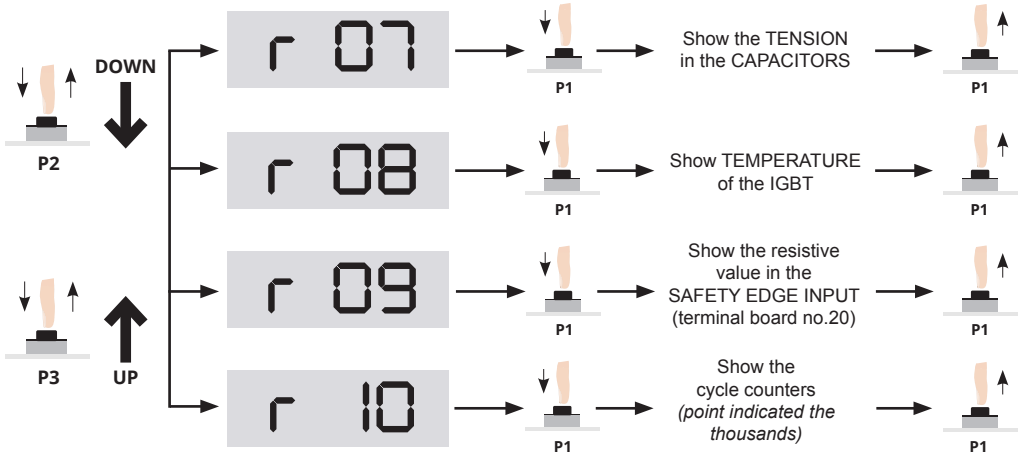

2.4. SET UP A PASSWORD FOR PROGRAMMING

To save all changes it is possible to select a password of 4 numbers. To activate this function make as follow:

- Password activation:**
Press **P1**, **P2** and **P3** in the function **S32** and then confirm with **P1**.

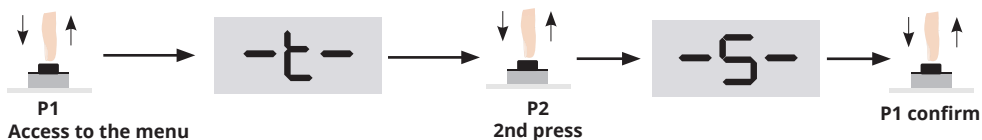

In the function **S** if you press **P1**, you can choose the group function: first select **P2**, now you can go to the function **S32** and then confirm with **P1**.

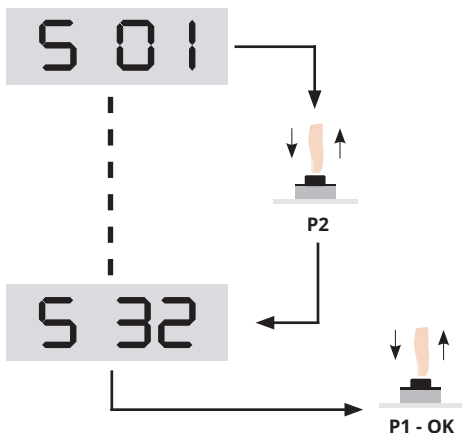

• INSERT PASSWORD

Choose the first number with the buttons **P2** and **P3** then confirm with **P1**. The same procedure applies to the other digits.



finished entering the 4 digit. Press **P1** to confirm. To cancel press **P1**, within 10 seconds. Otherwise, the next access will be required the security code.



Pay attention in case you forget the password it is not possible to enter in control board as well.

• Deactivation of THE password



If you select the function no. **S33** you can cancel the password. Wait 10 seconds to confirm the operation.

2.5. DISPLAY THE NUMBER OF CYCLES AND THE SPEED OF THE MOTOR

• Cycle counter

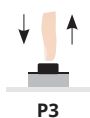

It is possible to show the number of cycles even pressing **P3** (*expressed in ten cycles*)

The counter counts up to 999'999 openings. The display shows the first 4 most significant digits.

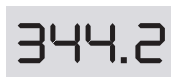

If you read these number, it means that the installation has made 344200 cycles.

• Motor speed

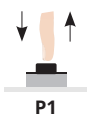

Press **P1** when the door is open, the display shows the SPEED of the MOTOR

2.6. DESACTIVATION OF THE CYCLE WHEN THE CONTROL PANEL WILL BE TURNED ON

When the tension has been interrupted and you turn on the control board again it will make a new cycle. To exclude this operation make as follow:



DESACTIVATE THE COMPLETE CYCLE OF THE CYCLE FUNCTION WHEN THE TENSION HAS BEEN INTERRUPTED: keep pressed **P1** when turns on.

3. INSTALLATION OF THE CONTROL UNIT

3.1. CONNECTION OF THE TENSION AND MOTOR POWER SUPPLY

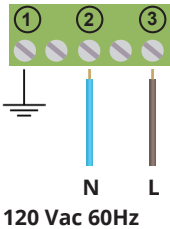

120 Vac 60Hz

- The control unit is equipped with a network filter



THREE-PHASE MOTOR CONNECTION (NO SINGLE-PHASE MOTOR)

We recommend:

- Install an automatic switch 10/16A
- Check the network power: 120 Vac: -5% +10%

3.2. CONNECTION OF THE LAMP 120 VAC OR 12 VDC

It is shown the connection of a **120V** lamp with or without flashing card.

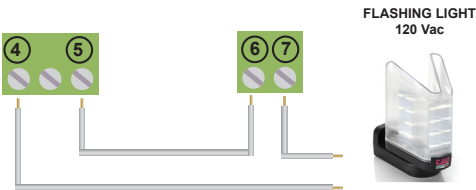

FLASHING LIGHT
120 Vac



It is shown the connection of a **12 Vdc** lamp with or without flashing card.

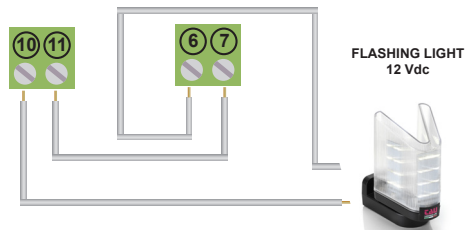

FLASHING LIGHT
12 Vdc



• Set up of the lighting

In case the lamp has no flashing card, set **S12** in 1:



FLASHING
1 - Activated (*standard*)
0 - Deactivated

• Lamp in pause time

To activate the function lamp in pause TIME, set **S05** as shown:



LAMP IN PAUSE
1 - Activated
0 - Deactivated (*standard*)

3.3. PRE-FLASHING TIME

It is possible to increase or reduce the time of pre-flashing when the door is closed or open, make as follow with **T07** and **T08**:



PRE-FLASHING TIME ON OPENING
From 0 to 10 s
Standard value 0.5 s



PRE-FLASHING TIME ON CLOSING
From 0 to 10 s
Standard value 2 s

3.4. CONNECTION OF THE AERIAL

In case the antenna is only a cable of 17cm for 433.92Mhz, connect it to the terminal board no. 23.

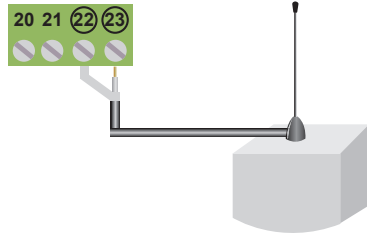

3.5. STOP CONNECTION

Button: Stop until a new command
Switch: it keep the automation stopped until a new command

| | |
|------|---|
| 5 15 | STOP 1 - Activated (<i>Default</i>) 0 - Deactivated |
|------|---|

The connection of the safety devices is prevued with a button or a normally closed contact
 More devices should be connected in parallel.

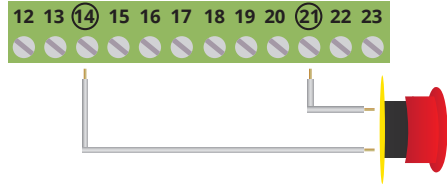

3.6. CONNECTION OF THE 8K2 SAFETY EDGE OR N.C. CONTACT

Connect the safety edge at terminal board no. 20 and 21

| | |
|------|--|
| 5 22 | SAFETY EDGE 0 - Deactivated 1 - Activated (<i>Default</i>) |
|------|--|

| | |
|------|---|
| 5 38 | SAFETY EDGE contact 0 - NC contact (normally closed) (<i>Default</i>) 1 - 8K2 contact |
|------|---|

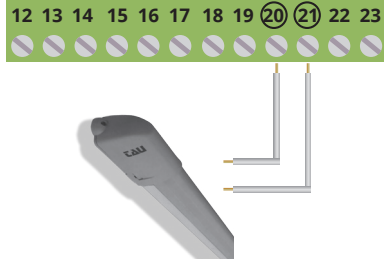

3.7. CONNECTION OF THE OPEN AND CLOSE LIMIT SWITCH

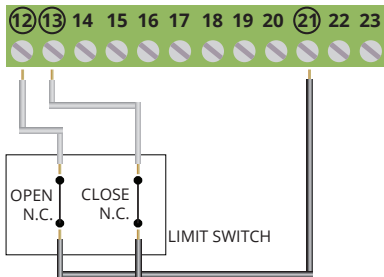

| | |
|------|---|
| 5 13 | LSO 1 - Activated (<i>Default</i>) 0 - Deactivated |
|------|---|

| | |
|------|---|
| 5 14 | LSC 1 - Activated (<i>Default</i>) 0 - Deactivated |
|------|---|



If the input LSO & LSC is not used, set S13 & S14 in 0

3.8. THE CONNECTION OF PEDESTRIAN OR OP/CL

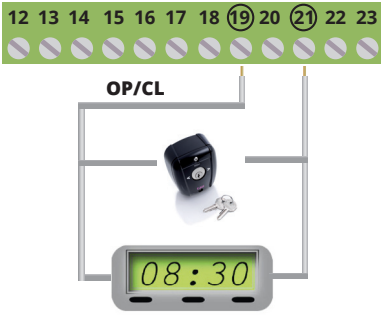

The connection of a OP/CL command can be done with a button or with a N.O. contact. When more devices are available, connect them in parallel.

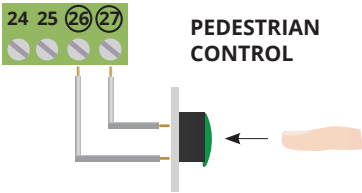

The connection of PEDESTRIAN can be done with a button or a normally open contact.

It is possible to connect a timer in the terminal board no. 19 and 21 to program the opening time of the gates. The contact of the timer should be normally open (N.O.) and it should be closed for all the time the gate is open. If the connection of opening command is available in the terminal board no 19, connect it in parallel.

3.9. CONNECTION OF THE PHOTOCELL (ONLY WHEN CLOSING)

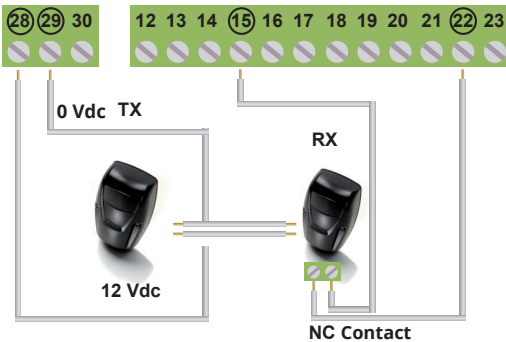

The contact of the receiver should be:
 - **Isolated** (*isolated from tensions*)
 - **Normally closed**



If the PHOTOCELL input is not used, S16 must be set to 0

3.10. CONNECTION OF THE PHOTOCELL (ACTIVATED WHEN CLOSING) WITH TEST

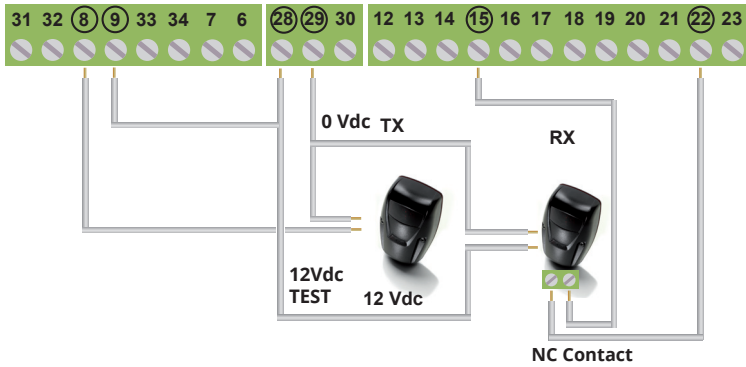

The TEST of the photo-beam works only if the photo-beams are installed properly. The control unit will check all connections before opening!

In case the photo-beam are not working properly the control unit will lit on for 5 seconds and the gate is not moving.

If you go back to function without TEST, do the connection as in Par. 3.9 and put in **0** the **S06** and **S09** (deactivate the latter only if there are no other inputs connected to TEST)

To activate the TEST set **1** in the **PHOTO-A**:

| | | | |
|------|--|------|--|
| 5 09 | TEST IN PHOTO OUTPUT 1 - Activated 0 - Deactivated (default) | 5 06 | TEST IN THE INPUT SAFETIES 1 - Activated 0 - Deactivated (default) |
|------|--|------|--|

4. ACTIVATE THE SINGLE OUTPUTS

D812M can open and close separately and the outputs for lamps and test. This is useful in case you want to check the single outputs.

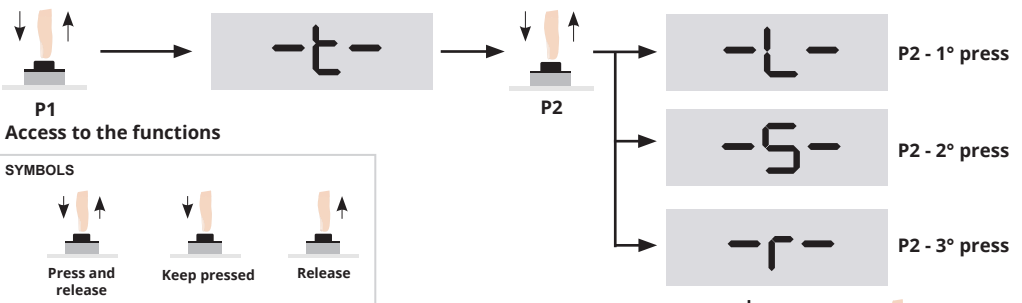

In the function **R** if you press **P1**, you can choose the subfunction group function: first select **P2** and **P3** and then confirm with **P1**. Now you can go to the function **R01**, **R02**, **R03** ...

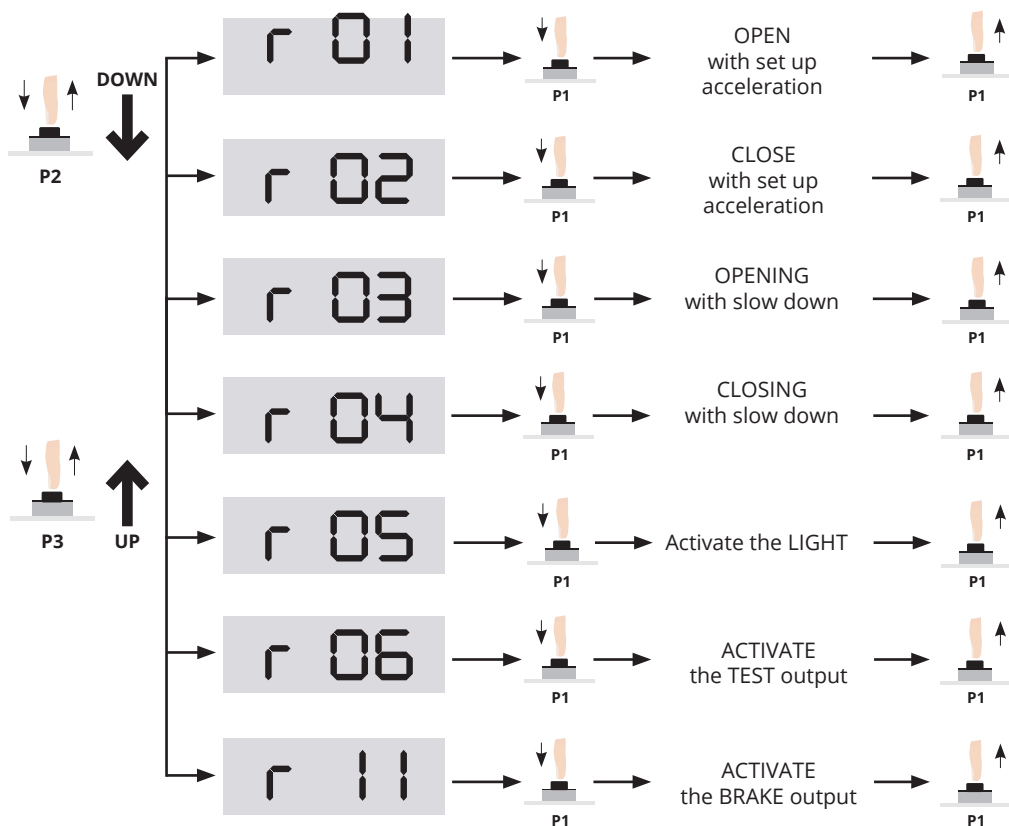

5. OPERATING MODES AND ADJUSTMENTS

5.1. LOGIC OF FUNCTIONS

| Imp. N° | | Functions | Description |
|-------------|----------|--|--|
| S 01 | 1 | Signal Reverse | By each START command inverts: OPEN-CLOSE It recloses automatically |
| | 2 | Automatic | The START command can open or recharge the pause time. It recloses automatically |
| | 3 | Bistable function | By each START command it follows: open-stop-close-stop-open... It doesn't recloses automatically |
| | 4 | Stable function with automatic reclosing after pause time | By each START command it opens-stops-closes-stops-opens... It recloses automatically after pause time |
| | 5 | Signal reverse + Dead-man function | Same as function S01 - 1 OPEN and CLOSE with "Dead-man function" function |
| | 6 | Collective use + Dead-man function | Same as function S01 - 2 OPEN and CLOSE with "Dead-man function" function |



| | | | |
|-------------|----------|--|---|
| | 7 | Bistable function + Dead-man function | Same as function S01 - 3 OPEN and CLOSE with "Dead-man function" function |
| | 8 | Bistable function with automatic reclosing after pause time + Dead-man function | Same as function S01 - 4 OPEN and CLOSE with "Dead-man function" function |
| S 02 | 1 | Reclosing when turning on (Standard value 0) | Complete open and close. ONLY when the tension has been interrupted when the gate is open. |
| S 04 | 1 | Photocell contact (Default 0) | Al passaggio rilevato dalle fotocellule, in apre se S07 è 0 imposta tempo di pausa a 2 s. |
| S 07 | 1 | Close after photocell (Default 0) | Put S04 in 1. When the following function is active on the passage detected by the photocells on opening, the control unit reverses the motor motion and closes. |
| T 18 | | Automatic opening after the time set (Default 00) | It is possible to activate the automation opening after the set time, from 1 to 99 minutes. (00 If the function is deactivated). Attention, choose a mode of operation with automatic reclosing. |

5.2. WORKING TIME

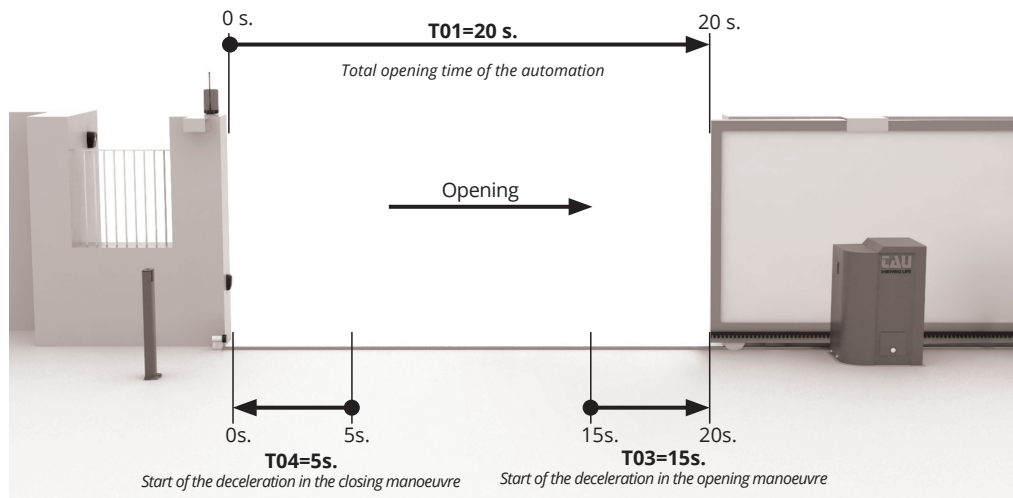
You can see how to program the control unit with **T** function:



| SET UP | DESCRIPTION | | VALUES ACCEPTED | STANDARD - seconds - |
|-------------|--|---------------|--------------------|----------------------|
| T 01 | Setting the total working time of the opening From the FCC closing limit switch to the FCA opening limit switch the time increases from 0s + 20s. Vice versa, from the FCA opening limit switch to the FCC closing limit switch, the time decreases from 20s + 0s (countdown). | step da 0,1 s | front 0,1 to 990 s | 20,0 |

| | | | | |
|-------------|--|------------------|-----------------------|------|
| T 02 | Setting the pedestrian opening time | step da 0,1 s | front 0,1 to 990 s | 3,0 |
| T 03 | Setting the starting slowdown position on opening  If we want the gate to slow down the last 5s, just set 15s on T03 and the gate will start to slow down from 15s to 20s. <i>Ex.: T01 = 20s assumed slowdown time = 5s</i> | step da 0,1 s | front 0,1 to 990 s | 15,0 |
| T 04 | Setting the starting slowdown position on closing  To set the slowdown on closing, the work time works as a countdown, so if we want the gate to slow down the last 5s, just set 5s on T04 and the gate will start to slow down from 5s to 0s. <i>Ex.: T04 = 5s When T01 reaches 5s from 20s, the slowdown starts.</i> | step da 0,1 s | front 0,1 to 990 s | 5,0 |
| T 10 | Extra time for limit switch search  In order to avoid that, due to errors in counting the operating time, the motor cannot open or close completely, an extra limit switch search time can be set. We recommend setting at least 5 s as per DEFAULT | step da 0,1s | da 0,1 a 990s | 5,0 |

5.3. SET SPEED AND ACCELERATION

Are now given the parameters that allow you to set SPEED, ACCELERATION and ABSORPTION:

| Set up | Description | Values accepted | Default |
|---------------|---|------------------------|----------------|
| L 01 | <i>Minimum speed OPENING</i> | <i>from 1 to 50</i> | 30 |
| L 02 | <i>Minimum speed CLOSING</i> | <i>from 1 to 50</i> | 30 |
| L 03 | <i>Maximum speed OPENING</i> | <i>from 1 to 100</i> | 80 |
| L 04 | <i>Maximum speed CLOSING</i> | <i>from 1 to 100</i> | 80 |
| L 05 | <i>OPENING acceleration</i> | <i>from 1 to 99</i> | 8 |
| L 06 | <i>CLOSING acceleration</i> | <i>from 1 to 99</i> | 8 |
| L 07 | <i>OPENING deceleration</i> | <i>from 0 to 25</i> | 8 |
| L 08 | <i>CLOSING deceleration</i> | <i>from 0 to 25</i> | 8 |
| L 09 | <i>Motor absorption in case of STOP</i> | Ampere | 13,0 |
| L 10 | <i>Motor absorption in case of problems</i> | Ampere | 14,0 |
| L 11 | <i>Power in the BRAKE OUTPUT</i> | <i>from 1 to 70</i> | 50 |

5.4. SCHEME RELATION BETWEEN SPEED AND FREQUENCY OF THE MOTOR

Here is the relation between speed and frequency of the motor:

| SPEED SETTING | FREQUENCY [Hz] |
|--------------------------|---------------------------|
| 1 | 12 |
| 5 | 14.50 |
| 10 | 17.00 |
| 15 | 19.50 |
| 20 | 22.00 |
| 25 | 24.50 |
| 30 | 27.00 |
| 35 | 29.50 |
| 40 | 32.00 |
| 45 | 34.50 |
| 50 | 37.00 |
| 55 | 39.50 |
| 60 | 42.00 |
| 65 | 44.50 |
| 70 | 47.50 |
| 75 | 49.50 |
| 80 | 52.00 |
| 85 | 54.50 |
| 90 | 57.00 |
| 95 | 59.50 |
| 100 | 62.00 |

6. RESET OF THE CONTROL UNIT AND RESTORE OF FACTORY DEFAULT SETTINGS

The control unit allows the parameters to be reset to their DEFAULT value (see par. 6.1), and also allows you to recall parameters stored specifically for the operation of the sliding gates.

6.1. RESTORE FACTORY SETTINGS

Checking those parameter of the parameters (Chapter no.7), you can look the set up during the RESET of the control unit. Select the paragraph S18 as shown:

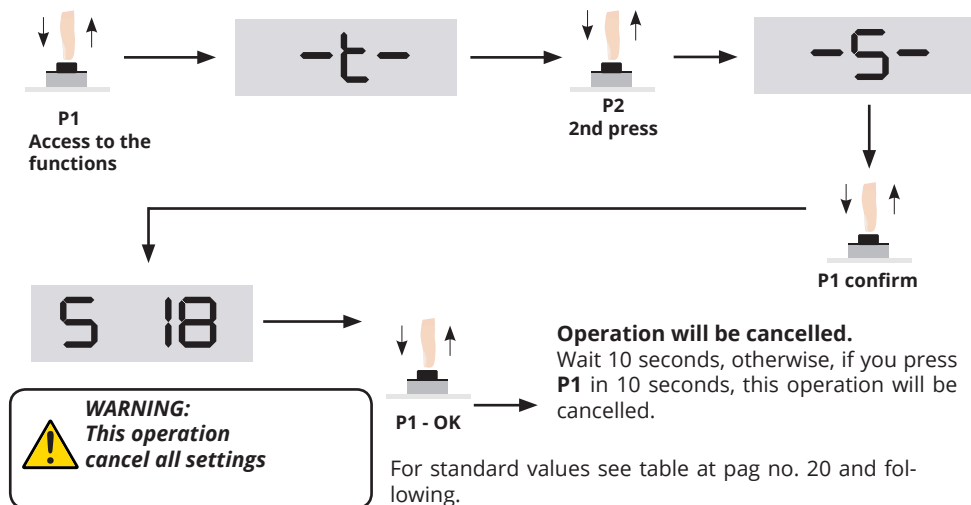

6.2. SAVE SET UP AND CHECK OF THE PARAMETERS

D812M has **2 memory slots** saving all manually set up and you can check it again. See how to check the set up with functions **S23**, **S24**, **S25**, **S26**. Once all parameters are set up, it is possible to change.

Thanks of the 2 memory slots, it is possible to save and check 2 differents set up.

• MEMORIA 1 (slot 1)

S 23

Press **P1**
Save all set up
MEMORY 1

S 25

Press **P1**
Charge set up of
MEMORY 1

• MEMORIA 2 (slot 2)

S 24

Press **P1**
Save all set up
MEMORY 2

S 26

Press **P1**
Charge set up of
MEMORY 2

7. LIST OF THE FUNCTIONS D812M

| Group functions "T" | | | | | |
|---------------------|--|-----------------|-------------------|----------------------|------|
| SET UP | DESCRIPTION | | VALUES ACCEPTED | STANDARD - seconds - | MEMO |
| T 01 | Complete opening cycle time | step from 0,1 s | from 0,1 to 990 s | 20,0 s | |
| T 02 | Partial opening time | step from 0,1 s | from 0,1 to 990 s | 3,0 s | |
| T 03 | Setting the starting slowdown position on opening | step from 0,1 s | from 0,1 to 990 s | 15,0 s | |
| T 04 | Setting the starting slowdown position on closing | step from 0,1 s | from 0,1 to 990 s | 5,0 s | |
| T 05 | Automatic closing time | step from 0,5 s | from 2 to 127.5 s | 2,0 s | |
| T 06 | Pause time for PARTIAL OPENING | step from 0,5 s | from 2 to 127.5 s | 5,0 s | |
| T 07 | PRE-LIGHTING time by opening | step from 0,5 s | from 2 to 127 s | 0,5 s | |
| T 08 | PRE-LIGHTING time by closing | step from 0,5 s | from 2 to 127 s | 2,0 s | |
| T 09 | <i>(Not used)</i> | | | | |
| T 10 | Extra time for limit switch search | step from 0,1 s | from 0,1 to 990 s | 5,0 s | |
| T 11 | Stop the detection of input of the photo-beam. Not considered if S03 is set 1 | step from 0,1 s | from 0,1 to 990 s | 0,5 s | |
| T 12 | <i>Time to stop to detect the SAFETY EDGE INPUT (terminal board. 16)</i> | step from 0,5 s | from 0,1 to 2 s | 1,0 s | |
| T 13 | Time block the check of the absorption of the motor when the gate is opening or closing | step from 0,1 s | from 0 to 2 s | 0,2 s | |
| T 14 | Pause time of reverse of the direction of the motor | step from 0,1 s | from 0 to 2 s | 0,1 s | |
| T 15 | STOP of the motor after detecting the LSO | step from 0,1 s | from 0 to 3 s | 0 s | |
| T 16 | Time of delay of the motor when detecting the LSC | step from 0,1 s | from 0 to 3 s | 0 s | |
| T 17 | Lead time on the release of the brake before starting the engine <i>(in tenths of seconds)</i> | | from 0 to 20 | 12 | |
| T 18 | Automatic opening after the time set <i>(00 If the function is deactivated)</i> | step from 1 min | from 00 to 99 min | 00 Deactivated | |

| Group functions "L" | | | |
|----------------------------|--|----------------------------|-----------------------------|
| SET UP | DESCRIPTION | VALUES ACCEPTED | STANDARD - seconds - |
| L 01 | Minimum opening speed | from 1 to 50 | 30 |
| L 02 | Minimum closing speed | from 1 to 50 | 30 |
| L 03 | Maximum opening speed | from 1 to 100 | 80 |
| L 04 | Maximum closing speed | from 1 to 100 | 80 |
| L 05 | Opening acceleration | from 1 a 10 | 5 |
| L 06 | Closing acceleration | from 1 a 10 | 5 |
| L 07 | Opening deceleration | from 0 to 10 | 5 |
| L 08 | Closing deceleration | from 0 to 10 | 5 |
| L 09 | Maximum absorption of the motor to STOP the door | in Ampere from 0,5 to 15,5 | 13,0 |
| L 10 | Maximum absorption of the motor in case of trouble | in Ampere from 0,5 to 15,5 | 14,0 |
| L 11 | Power of the output BRAKE | from 0 to 70 | 50 |

| Group functions "S" | | | | |
|----------------------------|--|-----------------------------|-----------------|-------------|
| SET UP | DESCRIPTION | VALUES ACCEPTED | STANDARD | MEMO |
| S 01 | <i>Logic of the motor:</i> 1 - Fast reverse 2 - Collective use 3 - Bistable function 4 - Bistable function with automatic reclosing 5 - Fast reversing and "Dead's man" function 6 - Collective use and "Dead's man" function 7 - Bistable function and "Dead's man" function 8 - Bistable function with automatic reclosing and "Dead's man" function | from 1 to 8 | 4 | |
| S 02 | Opening-closing cycle when the door is not closed | 0 Off - 1 On | 0 | |
| S 03 | Deactivate the input PHOTO A after intervention of the slow down LSC | 0 Deactivated - 1 Activated | 0 | |
| S 04 | Photocell contact activation | 0 Off - 1 On | 0 | |

| | | | |
|-------------|---|-----------------------------|---|
| S 05 | Signal light in pause time | 0 Off - 1 On | 0 |
| S 06 | Activation TEST in the safeties inputs | 0 Off - 1 On | 0 |
| S 07 | Close after photocell | 0 Off - 1 On | 0 |
| S 08 | NOT USED | leave on 2 | 2 |
| S 09 | Activate the TEST in the input PHOTOCELL | 0 Off - 1 On | 0 |
| S 10 | Activate the TEST in the SAFETY EDGE input | 0 Off - 1 On | 0 |
| S 11 | Activate the TEST in the input STOP | 0 Off - 1 On | 0 |
| S 12 | Activate the flashing in the signal light input | 0 Off - 1 On | 1 |
| S 13 | Activate the input LSO | 0 Off - 1 On | 1 |
| S 14 | Activate the input LSC | 0 Off - 1 On | 1 |
| S 15 | Activate STOP input | 0 Off - 1 On | 1 |
| S 16 | Activate the PHOTOCELL by closing | 0 Off - 1 On | 1 |
| S 17 | Security | 0 Off - 1 On | 0 |
| S 18 | Reset of the control unit at factory's settings | | |
| S 19 | NOT USED | | |
| S 20 | Activated the input SWITCH for opening slowing down | 0 Off - 1 On | 0 |
| S 21 | Activate the input swicht for CLOSING slowing down | 0 Off - 1 On | 0 |
| S 22 | Activate the input for SAFETY EDGE (terminal 20-21) | 0 Deactivated - 1 Activated | 1 |
| S 23 | Copy set up of memory 1 | | |
| S 24 | Copy set up of memory 2 | | |
| S 25 | Charge the set up of memory 1 | | |
| S 26 | Charge the set up of memory 2 | | |

| | | | | |
|------|--|---|--|---|
| S 27 | Charge the standard set up 1 | | | |
| S 28 | Charge the standard set up 2 | | | |
| S 29 | Charge the standard set up 3 | | | |
| S 30 | Charge the standard set up 4 | | | |
| S 31 | Charge the standard set up 5 | | | |
| S 32 | Activate of a password to set up with a code of 4 numbers. Put the new code and let the time goes. | | | |
| S 33 | You can deactivate the access of the set up with a password | | | |
| S 34 | Activation of the security closing after intervention of the edge (20-21) | 0 deactivated - 1 activated | | 0 |
| S 35 | NOT USED | leave on 0 | | 0 |
| S 36 | NOT USED | leave on 0 | | 0 |
| S 37 | Integrated electric brake (activated for 2 seconds after motor stopping) | 1= light acceleration 4 = heavy acceleration 5=neither acceleration nor braking 6= light braking 9= heavy braking | | 4 |
| S 38 | Safety edge - contact terminal board no.20-21 | 0: N.C. contact - 1: 8K2 contact | | 0 |
| S 39 | Opening / Closing in case of emergency | 0 deactivated - 1 activated | | 0 |

| Group functions "R" | |
|---------------------|---|
| SET UP | DESCRIPTION |
| R 01 | Activate Opening until P1 has been released with acceleration set up |
| R 02 | Activate CLOSING until P1 has been released with acceleration set up |
| R 03 | Activate the OPENING until P1 has been released with slow down acceleration |
| R 04 | Activate CLOSING until P1 has been released with slow down set up |
| R 05 | Activate LIGHT/SIGNAL LIGHTH until P1 has been released |
| R 06 | Activate TEST output until P1 has been released |
| R 07 | Display the tension of the capacitors until P1 has been released |
| R 08 | Display temperature of the IGBT until P1 has been released |
| R 09 | Display the resistive value in the SAFETY EDGE input (terminal board no.20) until P1 has been released |
| R 10 | Display the number of cycles number of cycles until P1 has been released (<i>point indicated the thousands</i>) |

8. PROBLEMS

Here are listed some functions issue indicated in the display. You can see the causes and the procedure to solve the issue..

| PROBLEM | DESCRIPTION | SOLUTION | | | | | | |
|---|---|--|------|------|------|--|-----------------------------|-------------------------------|
| Er01 | OVERVOLT on bus | There is a tension of 125 Vac in the capacitors. <i>Check the network tension.</i> | | | | | | |
| Er02 | OVERCURRENT in the MOTOR | The overcurrent level of programm L10 has been exceeded. <i>If necessary increase the value.</i> | | | | | | |
| Er03 | Tension in the capacitors too low | The tension in the capacitors is too low. <i>Check the network tension.</i> | | | | | | |
| Er04 | Absorption at 1.5 A when the motor is not working | The control unit has an absorption of more than 1,5A even if the motor is not working. <i>Check the accessories and the motor.</i> | | | | | | |
| Er05 | Security code not correct | Code not correct. <i>Try a new code.</i> | | | | | | |
| Er06 | Exceeded temperature of the spendthrift IGBT | <i>Wait until the temperature in the spendthrift is reduced.</i> | | | | | | |
| <table border="0"> <tr> <td style="padding: 2px;">Er07</td> <td style="padding: 2px;">Er 17</td> </tr> <tr> <td style="padding: 2px;">Er27</td> <td style="padding: 2px;">Er67</td> </tr> <tr> <td style="padding: 2px;">Er77</td> <td></td> </tr> </table> | Er07 | Er 17 | Er27 | Er67 | Er77 | | Signal error of the encoder | Check the encoder connections |
| Er07 | Er 17 | | | | | | | |
| Er27 | Er67 | | | | | | | |
| Er77 | | | | | | | | |

9 Note

.....

.....

.....

.....

.....

.....

.....

.....

.....

.....

10 Declaration of CE conformity

(according to EC Directive 2006/42, Attachment II, part 1, ses. A)

The undersigned **Loris Virgilio Danieli**,
Administrator

DECLARES THAT:



Company:

TAU S.r.l.

Address:

Via Enrico Fermi, 43
36066 Sandrigo (VI) Italia

Product's name:

D812M25
Centrale Inverter 120 Vac

| | |
|-----------------------------|---|
| THE PRODUCT COMPLIES | with what is outlined in the European Community directive: |
|-----------------------------|---|

| | |
|-------------------|---|
| 2006/42/CE | EC DIRECTIVE 2006/42 ISSUED BY THE EUROPEAN PARLIAMENT AND COUNCIL on may 17, 2006 harmonizing the legislation of the member countries regarding machinery. |
|-------------------|---|

Reference: Attachment II, part 1, ses. A (EC Declaration of Conformity issued by the manufacturer).

| | |
|-----------------------------|--|
| THE PRODUCT COMPLIES | with what is outlined in the European Community directives: |
|-----------------------------|--|

| | |
|-------------------|---|
| 2014/35/CE | DIRECTIVE 2014/35/EU OF THE EUROPEAN PARLIAMENT AND OF THE COUNCIL of 26 February 2014 on the harmonisation of the laws of the Member States relating to the making available on the market of electrical equipment designed for use within certain voltage limits. |
|-------------------|---|

Reference to harmonized standards: EN 60335-1

| | |
|-------------------|---|
| 2014/30/CE | DIRECTIVE 2014/30/EU OF THE EUROPEAN PARLIAMENT AND OF THE COUNCIL of 26 February 2014 on the harmonisation of the laws of the Member States relating to electromagnetic compatibility. |
|-------------------|---|

Reference to harmonized standards: EN 61000-6-2 EN 61000-6-3

| | |
|--------------------------------|---|
| IL PRODOTTO E' CONFORME | with the essential requirements of article 3 of the following European Community Directive, for the use for which the product is designede |
|--------------------------------|---|

| | |
|-------------------------|---|
| 2014/53/CE (RED) | DIRECTIVE 2014/53/EU OF THE EUROPEAN PARLIAMENT AND OF THE COUNCIL of 16 April 2014 on the harmonisation of the laws of the Member States relating to the making available on the market of radio equipment |
|-------------------------|---|

Reference to harmonized standards: ETSI EN 300 220-3 ETSI EN 301 489-1 ETSI EN 301 489-3

The directive 2006/42/CE remind that it is not allowed the function of the product until the machine, for which the product is included, is not indentify and declared conformed to the 2006/42/CE directive.

TAU S.r.l.
Via Enrico Fermi, 43
36066 Sandrigo (VI) Italia
Tel +39 0444 750190
Fax +39 0444 750376

info@tauitalia.com
www.tauitalia.com

Sandrigo, 01/06/2017
The Administrator
Loris Virgilio Danieli





Via Enrico Fermi, 43 - 36066 Sandrigo (VI) - Italy
Tel +39 0444 750190 - Fax +39 0444 750376
info@tauitalia.com - www.tauitalia.com